

HURRICANE SURF RACING



9'6"

FULL EPOXY NIPPER RACING BOARD | X-TECH



CONSTRUCTION

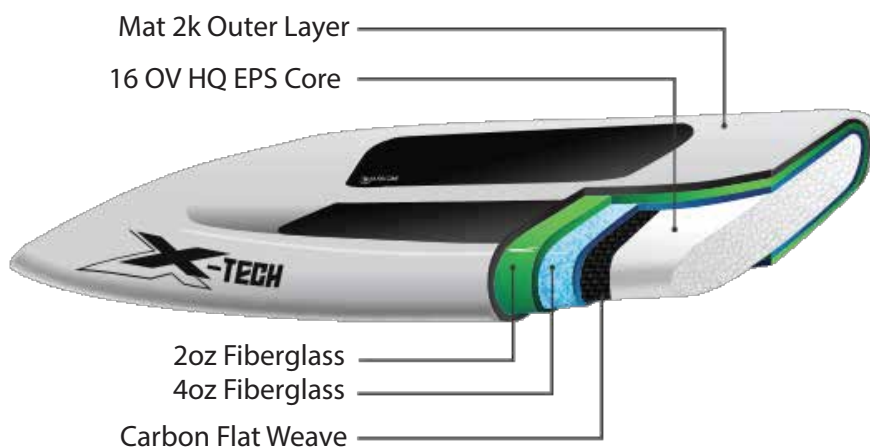

PRODUCT DESCRIPTION

The Ultimate Senior Rider Racing Board

- HQ EPS Core
- X-TECH Full Carbon Construction
- Side Grooves on both sides
- Soft EVA knee pads
- Suitable for u/12 RSA Nipper competition
- Board weight: 7kgs

Spray designs can be customized.

HURRICANE SURF RACING



10'6"

FULL EPOXY RACING BOARD | X-TECH



CONSTRUCTION

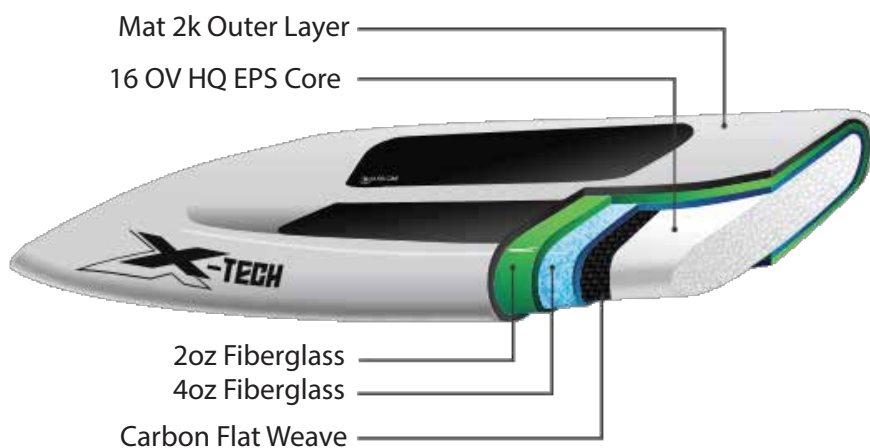

PRODUCT DESCRIPTION

The Ultimate Senior Rider Racing Board

HQ EPS Core
X-TECH Full Carbon Construction
Side Grooves on both sides
Soft EVA knee pads
Suitable for: All (500 - 900)
Board weight: 7.5kgs

Spray designs can be customized.

HURRICANE SURF RACING



12'0"

FULL EPOXY RACING BOARD | X-TECH



CONSTRUCTION

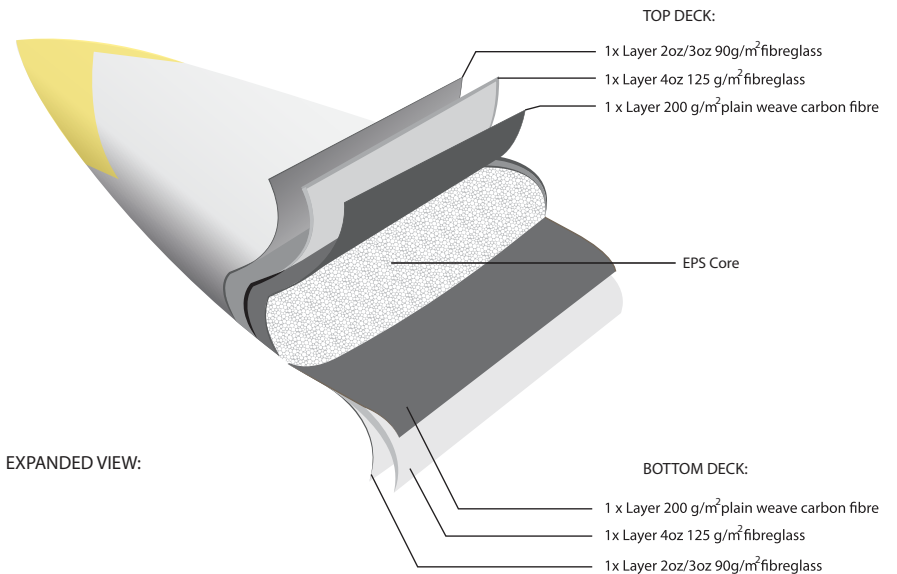

PRODUCT DESCRIPTION

12ft Stock Class Open Ocean Paddleboard

- HQ EPS Core
- X-TECH Full Carbon Construction
- Soft EVA knee pads
- Molokai board
- Board weight: 7 - 8kgs

Spray designs can be customized.

HURRICANE SURF RACING



EPOXY RACING BOARD | M-TECH



CONSTRUCTION

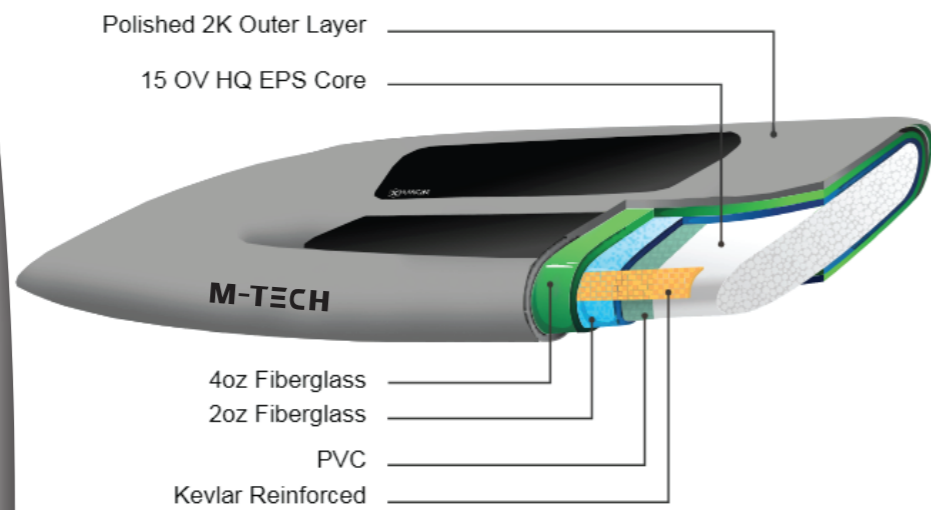

PRODUCT DESCRIPTION

The Ultimate Racing Board

- HQ EPS Core
- M-TECH PVC Sandwich Construction
- Side Grooves on both sides
- Soft EVA knee pads
- Suitable for: 600 series < 66kg
 700 series 67kg - 82kg
 800 series > 83kg

Board weight: 7.5 - 7.9kgs

M-TECH RACING BOARD DESIGNS

Spray 3a Spray 4b Spray 4c Spray 14a Spray 14c

Colour 1 Colour 2 Colour 3 Colour 4

Colour 1 Colour 2 Colour 3

Colour 1 Colour 2 Colour 3

Colour 1 Colour 2 Colour 3

Colour 1 Colour 2 Colour 3

Spray 15a Spray 16a Spray 16b Spray 16c

Colour 1 Colour 2 Colour 3

Colour 1 Colour 2

Colour 1 Colour 2

Colour 1 Colour 2

HURRICANE SURF RACING



2m Soft Top Nipper Racing Board | S-TECH



CONSTRUCTION

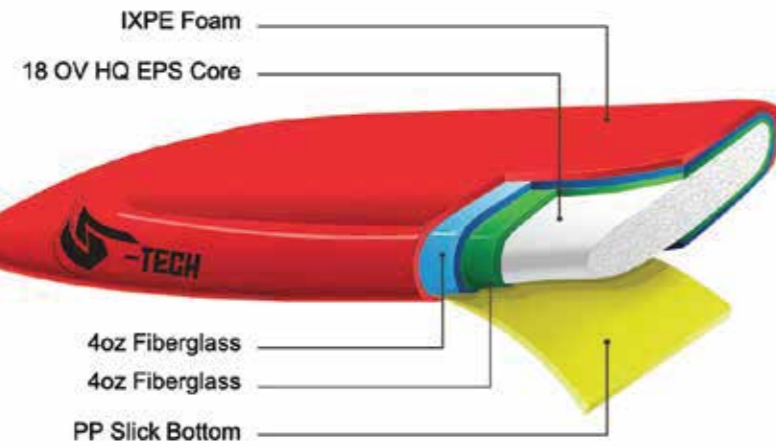

PRODUCT DESCRIPTION

2m Soft Top Nipper Racing Board

Features list as follows:

HQ EPS Core
Epoxy S-Tech construction with a PP Slick Bottom and IXPE Top

Board weight 4 - 6kgs

2M SOFT TOP NIPPER RACING BOARD DESIGNS

SPLAT
RED | WHITE | BLACK

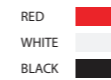

SPLAT
YELLOW | RED | BLACK

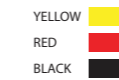

SPLAT
WHITE | RED | BLACK

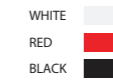

SPLAT
BLUE | ORANGE | BLACK

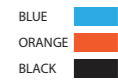

FF
RED | WHITE | BLACK

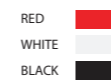

FF
YELLOW | RED | BLACK



FF
WHITE | RED | BLACK

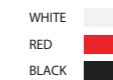

FF
BLUE | WHITE | BLACK



HURRICANE SURF RACING



2.6m Soft Top Nipper Racing Board | S-TECH



CONSTRUCTION

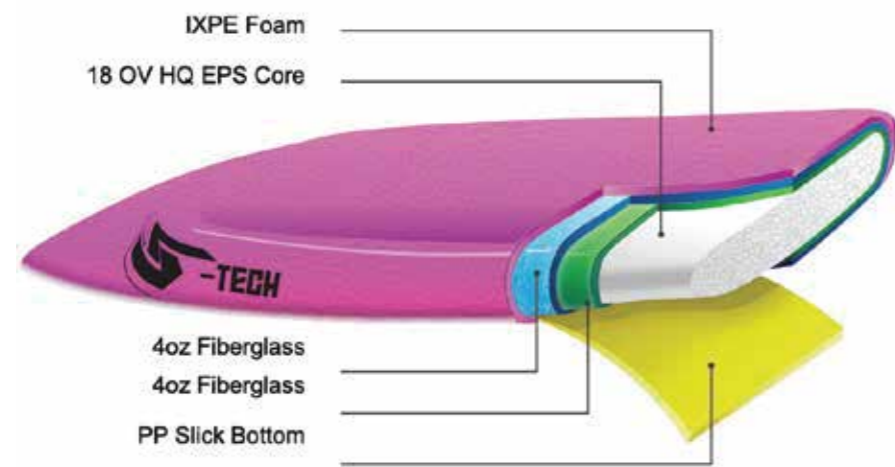

PRODUCT DESCRIPTION

2m Soft Top Nipper Racing Board

Features the following:

HQ EPS Core
Epoxy S-Tech construction with a
PP Slick Bottom and IXPE Top

Board weight 5-7kgs

2.6M SOFT TOP NIPPER RACING BOARD DESIGNS

SPLAT
RED | WHITE | BLACK



RED
WHITE
BLACK

SPLAT
YELLOW | RED | BLACK



YELLOW
RED
BLACK

SPLAT
WHITE | RED | BLACK



WHITE
RED
BLACK

SPLAT
BLUE | ORANGE | BLACK



BLUE
ORANGE
BLACK

FF
RED | WHITE | BLACK



RED
WHITE
BLACK

FF
YELLOW | RED | BLACK



YELLOW
RED
BLACK

FF
WHITE | RED | BLACK



WHITE
RED
BLACK

FF
BLUE | WHITE | BLACK



BLUE
WHITE
BLACK